

Features

- Two independent interfaces complying to DSI3 Bus Standard, revision 1.00, Feb. 16, 2011
- Suitable for fast data acquisition of sensors in signal function class
- Supports:
 - Point-to-point
 - Daisy chain bus
 - Parallel bus
- Versatile in-circuit configuration:
 - up to 15 DSI3-slaves
 - up to 16 packets per frame
 - 2 .. 63 bytes of average payload data per packet
 - supports EMC design by adjustable signal shapes
- Operating modes:
 - CRM - Command Response Mode
 - PDCM - Periodic Data Collection Mode
 - BDM - Background Diagnostic Mode
 - DM - Discovery Mode for address assignment in resistor connected daisy chain
- SPI interface

General Description

The E521.42 DSI3 master supports two independent DSI3-networks connecting sensor devices.

It provides physical and digital protocol handling according to the DSI3-bus standard. Besides established DSI3 applications it enables ultrasonic park assist sensor systems taking advantage of significantly increased data payloads. The E521.42 serves different numbers of slaves with different amount of acquired data. It allows network configuration in operation (TDMA scheme upload).

The IC includes a 140 words buffer for seamless acquisition of sensor data and exchange of control and configuration information.

The IC was developed according to ISO26262 as a safety element out of context with safety requirements rated ASIL B.

Ordering Information

Product ID	Temp Range	Package
E52142A52C	-40°C to +150°C	QFN20L4
E52142A52CXX2	-40°C to +150°C	QFN20L4 with SLP

Applications

- Ultra sonic parking assistant system
- DSI3 bus networks

Typical Application Circuit

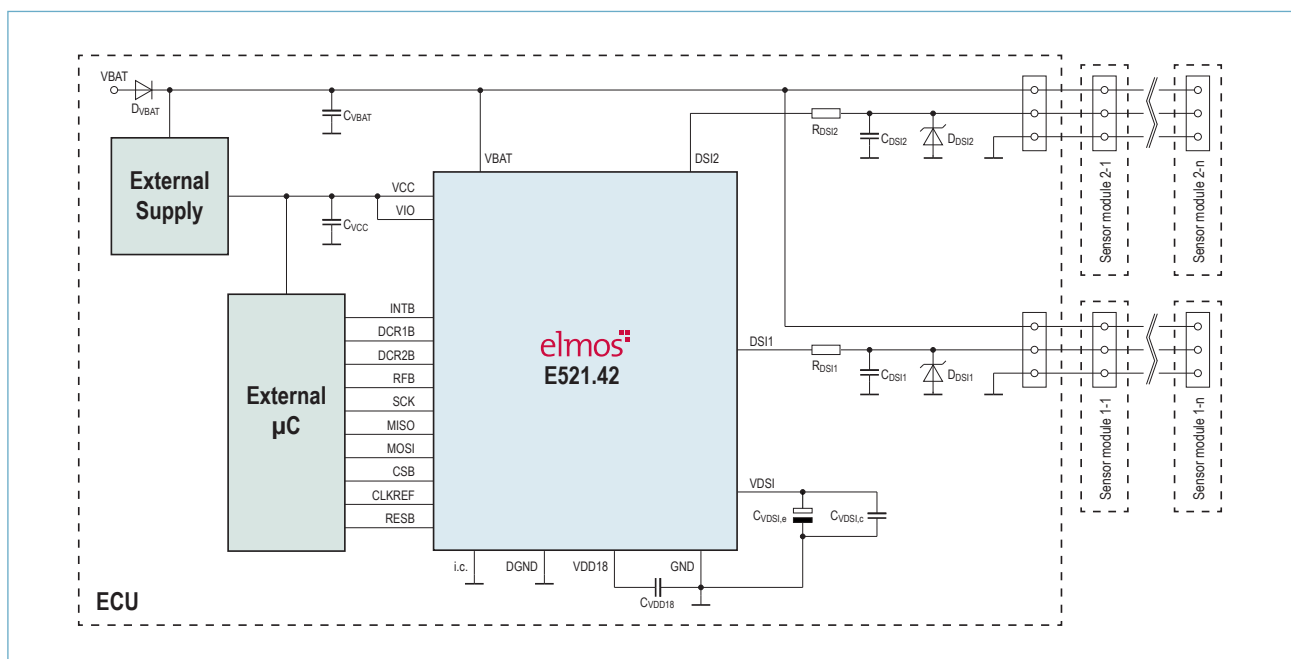

Elmos Support

Headquarters

Elmos Semiconductor SE
Heinrich-Hertz-Str. 1
44227 Dortmund (Germany)
Phone: +49 (0) 231 / 75 49-100
Fax: +49 (0) 231 / 75 49-149
sales-germany@elmos.com
www.elmos.com

Sales and Application Support Office North America

Elmos NA. Inc.
sales-usa@elmos.com

Sales and Application Support Office China

Elmos Semiconductor Technology (Shanghai) Co., Ltd.
sales-china@elmos.com

Sales and Application Support Office Korea

Elmos Korea
sales-korea@elmos.com

Sales and Application Support Office Japan

Elmos Japan K.K.
sales-japan@elmos.com

Sales and Application Support Office Singapore

Elmos Semiconductor Singapore Pte Ltd.
sales-singapore@elmos.com

Note: Elmos Semiconductor SE (below Elmos) reserves the right to make changes to the product contained in this publication without notice. Elmos assumes no responsibility for the use of any circuits described herein, conveys no licence under any patent or other right, and makes no representation that the circuits are free of patent infringement. While the information in this publication has been checked, no responsibility, however, is assumed for inaccuracies. Elmos does not recommend the use of any of its products in life support applications where the failure or malfunction of the product can reasonably be expected to cause failure of a life-support system or to significantly affect its safety or effectiveness. Products are not authorized for use in such applications.

Copyright © 2022 Elmos. Reproduction, in part or whole, without the prior written consent of Elmos, is prohibited.